

---

# NEWREX

NEWSLETTER

**Exchange Rate & Material  
Cost Report**

**Newrex  
New Order Delivery &  
Chinese Festival**

**Newrex  
2024 Taiwan International  
Fasterner Show**

**Exploring SAE J78 Steel  
Self-Drilling Tapping  
Screws**

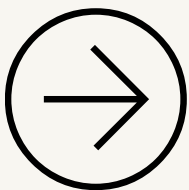
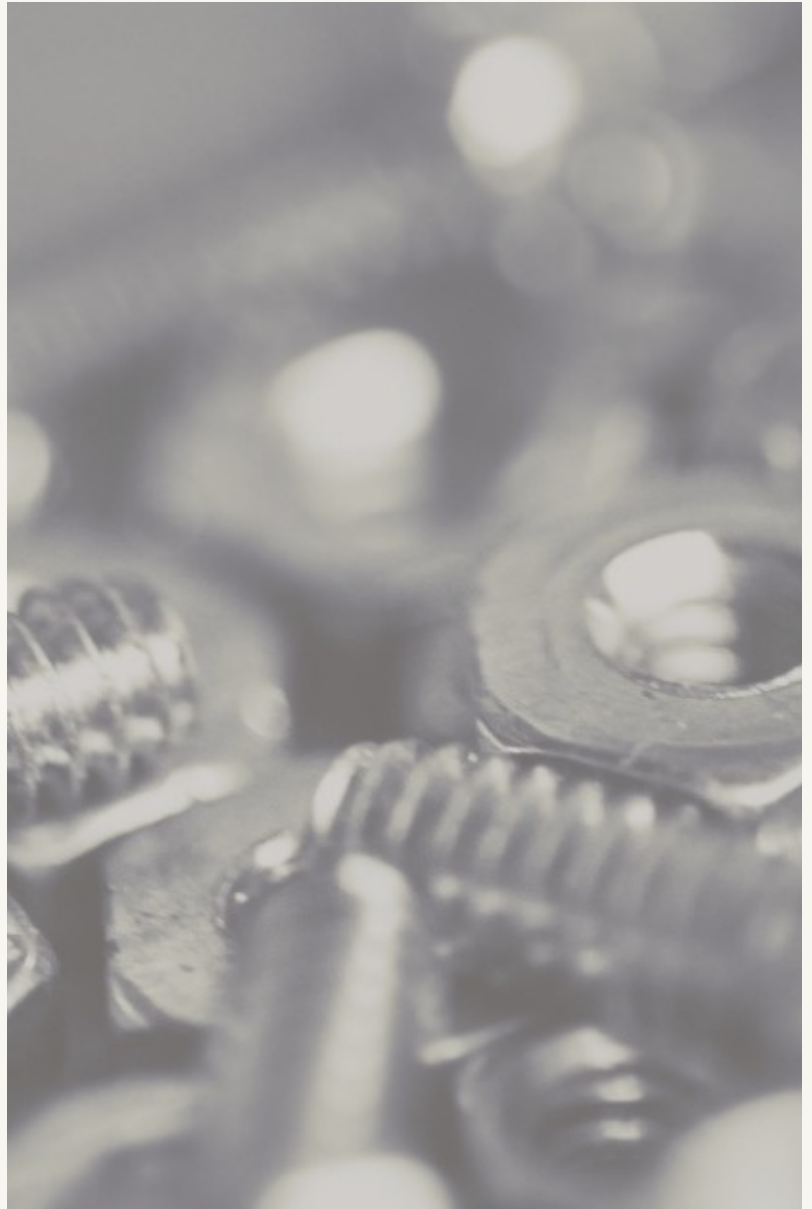

## 2024 Q2

# EXCHANGE RATE REPORT

2024 - Q1 (NEW TAIWAN DOLLAR TO U.S. DOLLAR)

The Taiwan dollar was trading at around NT\$31.95 to the US dollar on March 29. The exchange rate decreased 1.51% from January to March.

PLEASE REFER TO THE BELOW EXCHANGE RATE FLUCTUATION.



From: Bank of Taiwan - Spot Rate Buying (Monthly Average)

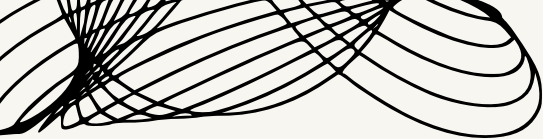

# EXCHANGE RATE REPORT

2024 - Q1 (NEW TAIWAN DOLLAR TO U.S. DOLLAR)

The Taiwan dollar was trading at around NT\$31.95 to the US dollar on March 29. Compared with last quarter, the average price of first quarter increased 1.22%

Compared with the same quarter last year, the average price of first quarter decreased 3.47%.

PLEASE REFER TO THE BELOW EXCHANGE RATE FLUCTUATION.



From: Bank of Taiwan - Spot Rate Buying (Monthly Average)

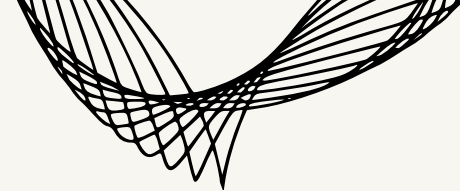

# MATERIAL COST REPORT

2024. Q2 (CARBON STEEL)

The price of carbon steel of 2024-Q2 is NT\$32,620/TON. The carbon steel price of 2024-Q2 was released on March 14th, and the price compared with last quarter is unchanged.

Compared with the same quarter last year, the price of second quarter in 2024 decreased 0.61%

PLEASE REFER TO THE BELOW CARBON STEEL FLUCTUATION

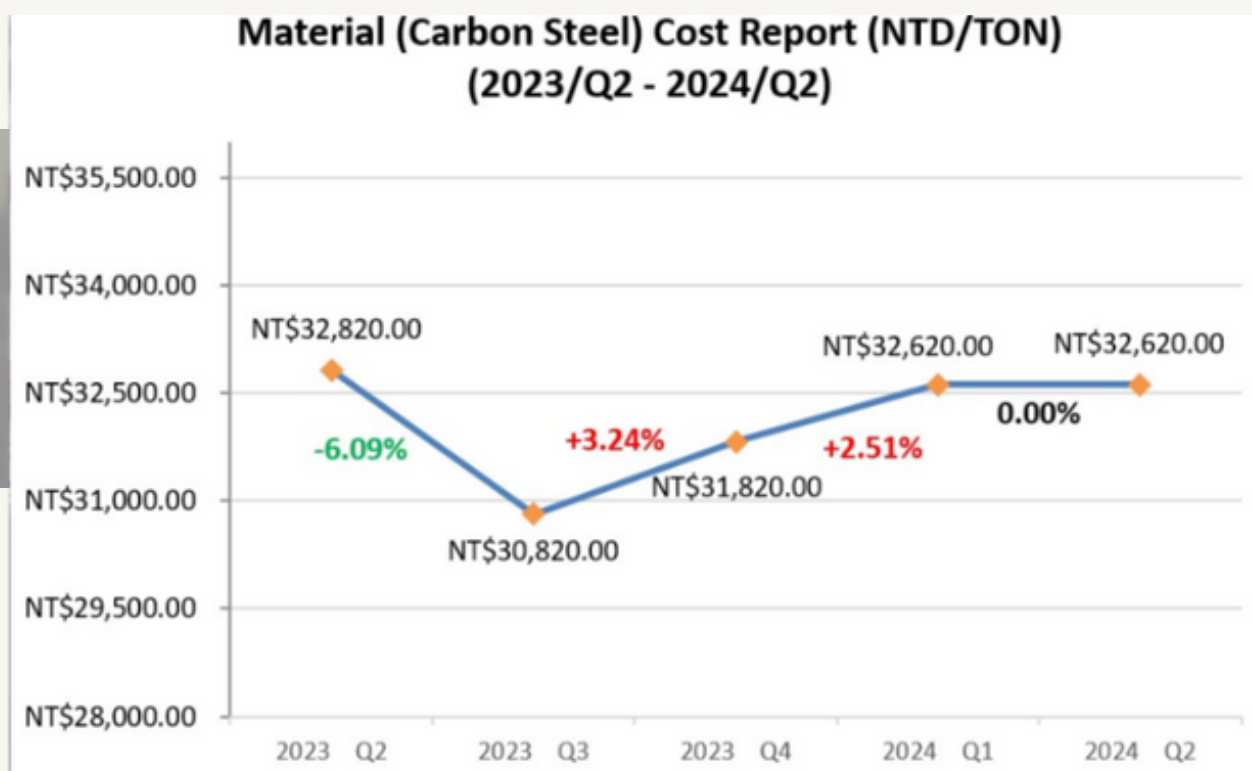

From: China Steel Corporation (CSC)



# MATERIAL COST REPORT

## 2024. Q1 (304 STAINLESS STEEL)

The average price of stainless steel in the first quarter, 2024, is NT\$186.33

Compared with last quarter, the average price of first quarter increased 0.72%.  
Compared with the same quarter last year, the average price of first quarter in 2024 increased 0.45%.



Taiwanese stainless steel mills' orders pick up slightly

(Data capture from: <https://yieh.com/en/NewsItem/143260>)

PLEASE REFER TO STAINLESS STEEL FLUCTUATION BELOW

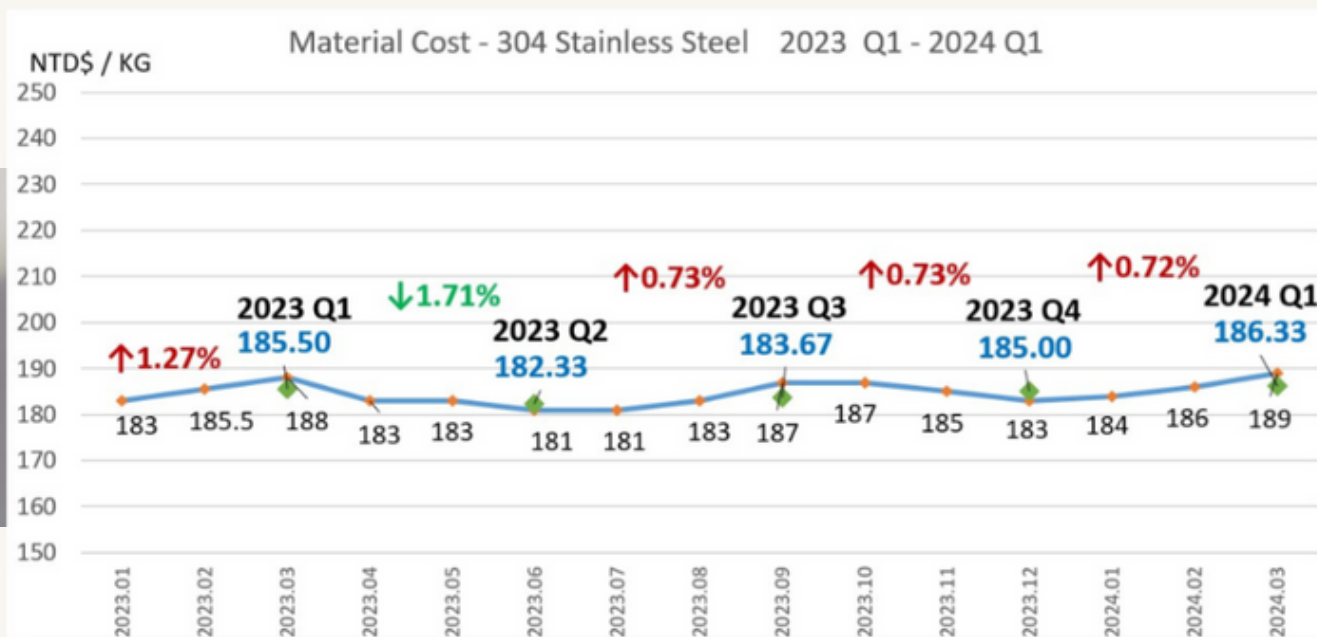

From: Provided from the suppliers

# NEWREX NEW ORDER DELIVERY

**Bolt & Screw**  
Quote Lead  
Time

2024-Q1

60-90 Days Approx.

**CNC**  
Quote Lead  
Time

2024-Q1

40-70 Days Approx.

# NEWREX NEW ORDER DELIVERY

Order Wire Material

10~20 Days



Production Process

30~45 Days



Heat Treatment

3~7 Days

Plating

3~7 Days



Packing

4 Days

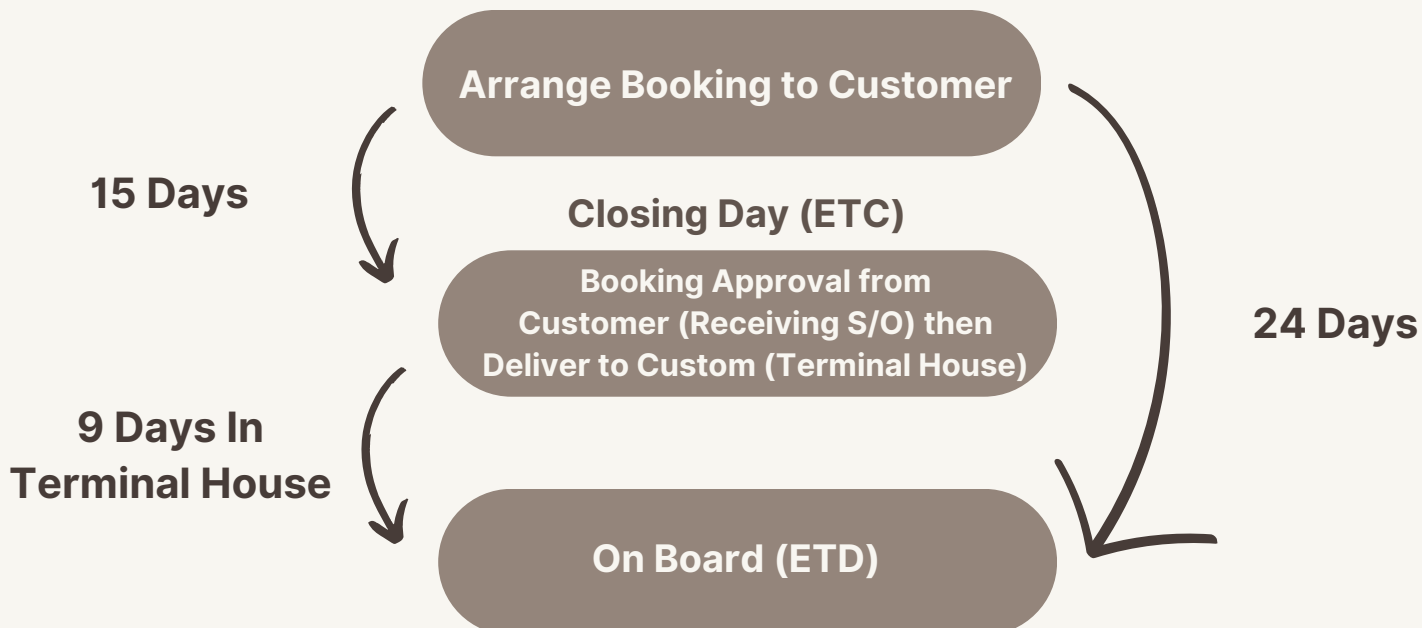

# Office Closed Notice

CHINESE FESTIVAL



	Office Close Dates	Resume Dates
<b>Tomb Sweeping Day</b>	2024/04/04   2024/04/07 (4 Days)	2024/04/08 (Monday)
<b>Labor Day</b>	2024/05/01 (1 Day)	2024/05/02 (Thursday)
<b>Dragon Boat Festival</b>	2024/06/10 (1 Day)	2024/06/11 (Tuesday)



2024

# TAIWAN INTERNATIONAL FASTENER SHOW



Newrex is going to meet you at 2024 Taiwan Fastener Show.

We are very excited to attend and look forward to meeting you all soon. Should you need any travel assistance, please let us know

**NEWREX BOOTH  
NUMBER -N2328**

**2024 06/05 - 06/07**

Kaohsiung Exhibition Center(No.39, Chenggong 2nd Road, Qianzhen Dist., Kaohsiung 806, Taiwan, ROC)

[https://www.fastenertaiwan.com.tw/en/ind\\_ex.html](https://www.fastenertaiwan.com.tw/en/ind_ex.html)

---

# Exploring SAE J78 Steel Self-Drilling Tapping Screws

---

1. Generally, in the United States, the standard used for Self-Drilling Tapping Screws is SAE J78, with sizes ranging from #4 to 1/4".
2. Screw Types: This document covers two types of self-drilling tapping screws:

## 2.1 TYPE BSD:

These screws feature spaced threads with drill points of varying configurations, denoted as Style 2, Style 3, Style 4, and Style 5, designed to accommodate different panel thicknesses.

## 2.2 TYPE CSD:

Type CSD screws have threads resembling unified form, with drill points also available in varying configurations designated as Style 2, Style 3, Style 4, and Style 5, catering to different panel thicknesses.



FIGURE 1

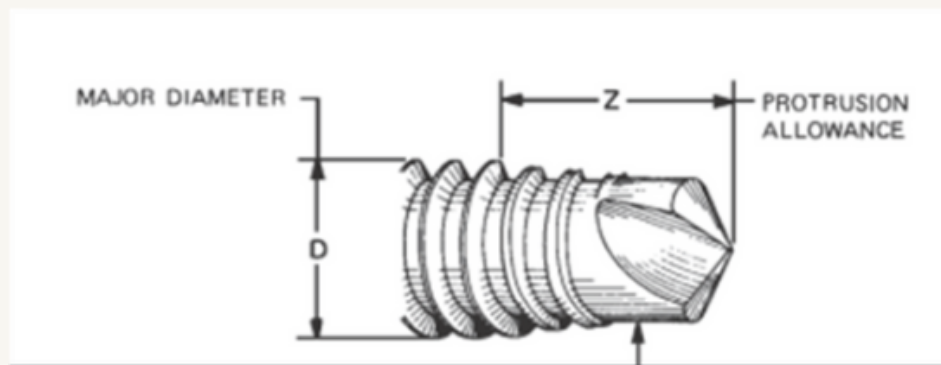

---

# Exploring SAE J78 Steel Self-Drilling Tapping Screws

---

## 3. Formation of Points:

Generally, there are two methods for forming points: MILLING (see Figure 2) and FORMED (see Figure 3), depending on the manufacturer's choice. Typically, the formed method is preferred.

**FIGURE 2**

Milled



**FIGURE 3**

Formed

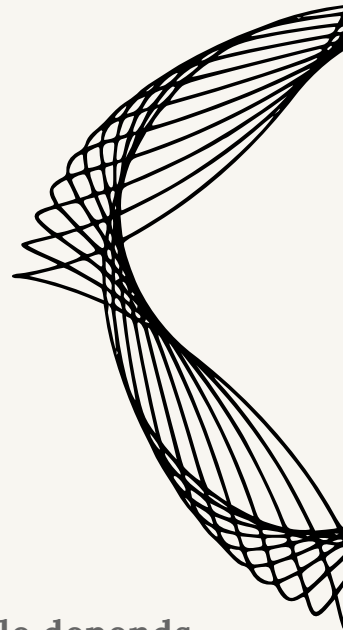

## 4. Point Style Selection:

As mentioned in Sections 2.1 and 2.2, the selection of point style depends on the thickness of the panel being fastened. The panel thickness should not exceed the point length (protrusion allowance) to prevent screw breakage, as the threading speed is faster than the drilling speed.

Generally, Style 2 is suitable for panels up to #8 thickness, while Style 3 is preferable for thicker panels starting from #10.

---

# Exploring SAE J78 Steel Self-Drilling Tapping Screws

---

---

## 5. Variations of Self-Drilling Tapping Screws:

Due to diverse applications, self-drilling tapping screws come in various forms. One common variation is the addition of wings, which are suitable for joining wood and metal panels (see Figure 4).

**FIGURE 4**

